

DETERMINATION OF ORIENTATION PARAMETERS AND AUTOMATIC WIND WHEEL SPEED CONTROL

Nurkimbayev Sagynysh*, Ivan Shumeiko, Assylbek Kassenov, Galya Itybaeva

Toraighyrov University, Faculty of metallurgy, machine building and transport, Pavlodar, Republic of Kazakhstan

*nurkimbayev.sagynysh@gmail.com

The design of the wind wheel and storm protection will help greatly improve the performance and safety of the wind-powered water-lifting unit. This, in turn, will contribute to improving the quality of life of rural residents. The authors of this study developed the design of a wind-powered water-lifting unit. The research aims to develop a wind-powered water-lifting unit with a capacity of up to 2.5 m³/hour, resistant to hurricane gusts of wind, with automatic control of wind wheel speed. The mathematical expressions used consider the force of the airflow and the screen area of the side blade, which takes the plane of the wind wheel out of the wind when it increases to values above the permissible operating wind speed. Numerical methods were used to calculate the forces on the spring returning the wind wheel plane to the initial position at different wind speeds. The dependences of the effect of airflow velocity on the free rotation of the wind wheel, i.e., without its running out of the wind, have been determined.

Keywords: torque, wind wheel mechanism, drilling protection mechanism, drilling protection, modeling

1 INTRODUCTION

At present in Kazakhstan and abroad there is extensive research in search of inexpensive but very effective ways of electric power generation and groundwater-lifting [1, 2]. Practice shows that complex wind power plant designs degrade their performance [3,7,8]. It is reasonable to use wind energy to lift groundwater using wind-powered water-lifting units, especially in areas remote from the central water supply. Analysis of known scientific and technical literature [4,5,6] has shown that it is possible to solve the problem of supplying points remote from water supply lines, as well as to offer an alternative option of water supply to residents of rural areas by installing wind-powered water-lifting units.

Modernization of wind-powered water-lifting units (WPWLU) occurs by increasing the power of the wind wheel (WW) without significant modifications to the design of water-lifting mechanisms.

The inconstancy of wind energy makes the technique of harnessing this energy extremely difficult. If the wind speed changes 2-3 times within a minute, the energy changes 8-27 times [9]. According to anemograph records, there are known cases when wind speed changed more than 4 times for one minute. At the same time, the working mechanism connected to the wind engine (pump) requires a certain power and speed, which must remain constant throughout the operation of these machines. Consequently, there is a need to regulate the wind engine, i.e., to have a constant number of revolutions at a given power, regardless of wind speed.

A promising way to solve this problem is to install a wind engine control unit, the operation of which is to change the position of the wind wheel or its blades in the airflow to obtain constant power and speed [10].

As part of the research work, the team of authors developed the design of WPWLU. Its twelve-bladed WW, as the main unit of the installation, is of maximum all-welded construction with sheet steel blades with variable concavity along the length of the helical shape, ensuring the constancy of the angle of attack of the airflow along the entire length of the blade [11]. Auxiliary base surfaces of WW welded body of flange type, allowing to install blades with initial nominal angle of jamming (setting) equal to 15°, accepted based on experience of operation of similar installations. WPWLU is equipped with a mechanism of storm protection and autonomous control of WW rotation frequency, made in the form of a side vane, which takes WW out of the wind at its strengthening, with a spring, which returns WW to the initial position at air flow weakening. To enhance the action of the airflow on the WW, a fairing was applied, directing the airflow in the central region, which previously did not perform work, to the blades.

2 RESEARCH METHODOLOGY

For experimental studies to confirm the results of theoretical calculations, a prototype wind-powered water-lifting unit (working model) was manufactured. Experimental studies of the dependence of torque, speed, and power developed by WW on its design parameters (shape of blades, their number, angle of installation, and relative area) were carried out with the help of a wind tunnel providing constant airflow velocity. Optimal design parameters were identified based on minimizing losses in torque, speed, and power. The results of the experimental studies presented in [12, 13, 14, 15, 16, 17, 18, 19] were used in the development of the design of WW and WPWLU.

The analysis of works devoted to the determination of optimal design parameters of WW shows that the greatest interest of researchers is directed to the choice of WW design, providing the maximum possible use of energy of the airflow passing through a unit area at different wind speeds [9].

As a result, it was found that, concerning WPWLU, it is most appropriate to use a twelve-bladed WW with sheet steel blades with variable concavity along the length of the helical shape, installation angle equal to 15° , and relative looseness equal to 0.05. The presence of a fairing, the diameter of which is taken as a function of the ratio of WW diameter to the fairing diameter, increases the airflow efficiency by 5 - 15%. During the experimental studies and their processing, it was assumed that the results obtained from the model studies were consistent with the designed ones.

As for the undoubtedly positive results of the above-mentioned studies, it should be noted that the accumulated material cannot be recognized as sufficient.

The analysis of the state of the art of the issue allowed us to outline further avenues of research:

1. Review the general methodology for calculating the wind wheel run-out mechanism.
2. Create a mathematical apparatus for determining the reduction in speed as the airspeed increases.
3. Conduct calculations to determine the effect of wind speed on the rated speed of the wind wheel for different wind wheel run-out angles and their corresponding rated performance.

3 RESULTS AND DISCUSSION

3.1 Calculation and justification of the main output parameters of the wind-powered water-lifting unit

Based on the operating experience of known WPWLUs [7,8,9] and water column pressure equal to 9.8 m, let's place the piston pump at the depth of $l_1=6\text{ m}$ (Fig. 1) in the casing. Let us take the height of water-lifting through a vacuum under the pump to be equal to $l_d=6\text{ m}$, which is significantly less than 9.8 m. Let us calculate the force on the pump thrust rod, considering the mass of the water to be lifted and the mass of the thrust rod with the piston. The mass of water consists of the mass of water in the pipe m_{wtr} with a flow area $d=25\text{ mm}$ and the mass of the lifted water in the pump cylinder m_{wc} . Let us first take the diameter of the pump piston equal to $D=75\text{ mm}$ and the length of the piston stroke l_3 equal to 200 mm . Then the mass of the lifted water, according to the performed calculations, considering its density, is assumed to be 5.28 kg.

The mass of the steel rod, made in the form of a standard round steel pipe with a diameter $d=16$ with a wall thickness of 2 mm and a length $l_4=l_1+H=600+600+200=1400\text{ cm}$, will be

$$m_t = 0,690 \cdot 14 = 9,66\text{ kg}$$

Total lifted weight m_Σ

$$m_\Sigma = 5,28 + 9,66 = 15\text{ kg}$$

The resulting mass corresponds to a gravity F equal to 150 N.

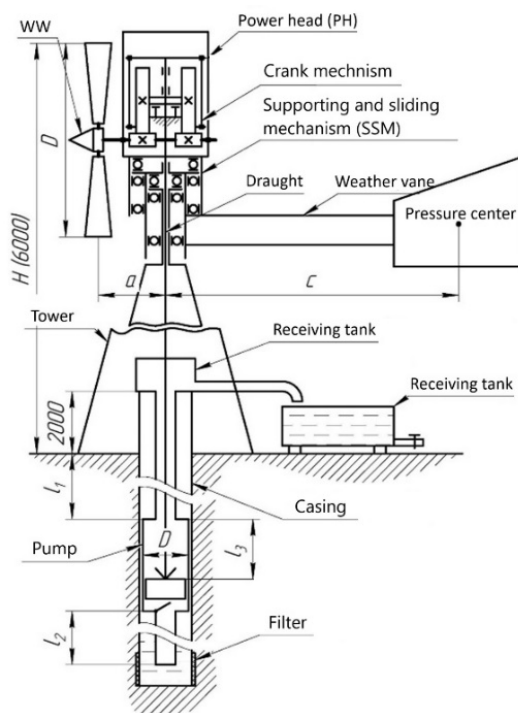

Fig. 1. Schematic diagram of a wind-powered water-lifting unit

Time of one double stroke of the pump piston at a given capacity $2,5\text{ m}^3/\text{hour}$:

In one double stroke, the volume of water lifted will be:

$$\frac{\pi D^2}{4} \cdot l_2 = \frac{\pi 7,5^2}{4} \cdot 20 = 883 \text{ cm}^3 = 0,883 \text{ l} \quad (1)$$

Then, the number of double moves per hour is $\frac{2000}{0,883} = 2240 \text{ move stroke/hour}$

Time of one double stroke $\frac{3600 \text{ s}}{2240 \text{ move stroke}} = 1,61 \text{ s}$.

The required minute power with a piston stroke length $l_3 = 0,2 \text{ m}$ is calculated by the formula:

$$N = \frac{A}{t} = \frac{F \cdot l_3}{t} = \frac{60 \cdot 150 \cdot 0,2}{1,61} = 1118 \text{ W} \quad (2)$$

Considering possible friction losses, we assume the required power to be 1.2 kW.

The power developed by WW is determined by the formula [9]

$$P = \rho \cdot \vartheta^3 \frac{\pi D^2}{4} \cdot \frac{\xi}{2} \quad (3)$$

where ρ is the density of air. For normal conditions $\rho = 1,29 \frac{\text{kg}}{\text{m}^3}$ (at $t = 15^\circ \text{C}$ and atmospheric pressure of 101.3 kPa or 760 mmHg).

ϑ - air flow velocity, m/s.

D - diameter of the wind wheel, m.

ξ - wind energy utilization factor, $\xi = 0,593$.

At a given power, from formula (3) it is possible to determine the diameter of WW

$$D = \sqrt{\frac{8P}{\rho \vartheta^3 \pi \xi}}$$

For the initial limiting operating wind speed, we take $9 - 11 \text{ m/s}$ and for the pre-selected power developed by the WW,

$$D = \sqrt{\frac{8 \cdot 1200}{1,29 \cdot 9^3 \cdot \pi \cdot 0,593}} = 2,34 \text{ m, let's accept } D = 2,6 \text{ m}$$

Fast speed, or the number of WW modules, as the ratio of the circumferential speed of the end of WW blades to the wind speed, can be determined by the formula [9]

$$Z = \frac{\pi R n}{30 \vartheta} \quad (4)$$

where R is the WW radius, equal to $R = 1,3 \text{ m}$.

Next, let's determine the nominal speed of WW at an airflow speed of 9 m/s, taken as the limiting operating speed.

The capacity of the pump we will accept equal to $Q = 2,0 \text{ m}^3/\text{hour}$, volume of lifted water for one double stroke we will accept equal to 0,84 liters/move stroke considering possible leaks.

The frequency of double piston strokes per minute for the required capacity will be:

$$n_{\text{move stroke}} = \frac{1200}{60 \cdot 0,84} = 39,68 \approx 40 \text{ move stroke/min.}$$

Considering the adopted gear ratio $i = \frac{1}{6}$, converting the rotary motion of the WW shaft into the reciprocating motion of the piston, the rotational speed will be:

$$n_{\text{WW}} = \frac{n_{\text{move stroke/min}}}{i} = \frac{40}{1/6} = 240 \text{ rpm.}$$

The speed of WW according to formula (2)

$$X = \frac{\pi \cdot 1,3 \cdot 240}{30 \cdot 9} = 3,63$$

WW rotation frequency for different values of wind speed provided that the WW is not carried away from the wind, can be determined by the formula [9]

$$n_{\text{max}} = \frac{60 \cdot X \cdot \vartheta}{\pi \cdot D} \quad (5)$$

$$\text{For } \vartheta_1 = 4 \text{ m/s, } n = \frac{60 \cdot 3,63 \cdot 4}{\pi \cdot 2,6} = 107 \text{ rpm,}$$

$$\text{for } \vartheta_2 = 6 \text{ m/s}, n = \frac{60 \cdot 3,63 \cdot 6}{\pi \cdot 2,6} = 160 \text{ rpm},$$

and so on. These WW speeds and all subsequent values are summarized in Table 1 under the letter symbol n_{max} .

Note: The absence of WW drifting out of the wind is allowed at wind speed up to 12 m/s and is ensured by locking the rotation of the platform with the power head. In case of a further increase in wind speed, the WW shall be driven out of the wind.

Table 1. Dependence of WW rotation frequency for different values of wind speed

Indicator	Current parameter values								
ϑ , m/s	4	6	8	9	10	12	14	18	22
n_{max}	107	160	213	240	267	320	-	-	-
Q_{max} , m ³ /hour	0,9	1,34	1,79	2,02	2,24	2,7	-	-	-

The values of WPWLU productivity for the obtained WW speeds can be determined by the formula:

$$Q_{max} = \frac{60 \cdot V \cdot n_{max} \cdot i}{1000}, m^3 / hour \quad (4)$$

where V is the volume of lifted water for 1 double stroke of the piston, l.

i - gear ratios, $i = \frac{1}{6}$

The parameters for the value of Q_{max} in m³/hour are summarized in Table 1.

3.2 Calculation of wind wheel orientation parameters and autonomous control of its rotation speed

Further, we will perform all necessary calculations on the choice of the areas of the vane screen, providing the WW plane installation towards the airflow and the screen of the side blade, taking the WW plane out from under the wind at its strengthening above the maximum allowable operating wind speed.

The area of the weather vane screen can be calculated by the formula [10]

$$A = D^2 \cdot \frac{a}{c} \cdot k_k \quad (5)$$

where A is the area of the weather vane, m².

a and c - dimensions, respectively, from the WW plane to the axis of rotation of the power head and from the axis of rotation to the center of the weather vane. (a and c are taken constructively and equal to $a = 0,46$ and $c = 1,625$ m).

D - WW diameter.

k_k - the coefficient adopted for slow-speed WWs. $k_k = 0,32$ [10]

$$A = 2,6^2 \cdot \frac{0,46}{1,625} \cdot 0,32 = 0,61 \text{ m}^2$$

We take it equal to 0.8m².

Calculate the force acting on the vane using formula 6:

$$F = \frac{N}{\vartheta} \cdot A \quad (6)$$

where N is the second power contained in the air stream having a cross-section of 1m² according to Table 2 [9].

ϑ - current value of airflow velocity, m/s.

Table 2. Dependence of second power contained in the air stream having a cross-section

Indicator	Current parameter values								
Wind speed ϑ , m/s	4	6	8	9	10	12	14	18	22
Flow capacity, kW/m ²	0,04	0,13	0,31	0,46	0,61	1,14	1,67	3,6	6,25

The calculated values of the force F and moment M_f generated by the force F on the arm equal to $c = 1,625$ m is summarized in Table 3. The torque is calculated assuming an airflow perpendicular to the vane plane.

Table 3. Dependence of the torque acting perpendicular to the vane plane

Indicator	Current parameter values								
ϑ , m/s	4	6	8	9	10	12	14	18	22
F , N	6	14	25	33	39	61	77	161	182
M_f , N·m	10	23	41	54	63	99	125	262	295

Next, let us calculate the power generated by the side vane WPWLU to move WW out of the wind by overcoming the elastic force of the spring, which returns WW to the initial position towards the airflow at its weakening. Two conditions must be met:

- WW should be run out only starting from the airflow speed equal to or greater than the operating wind speed of 8 m/s.
- The torque developed by the side vane must always be less than the torque developed by the WPWLU vane.

All subsequent calculations related to the calculation of WW run out of the wind will be performed according to Fig. 2.

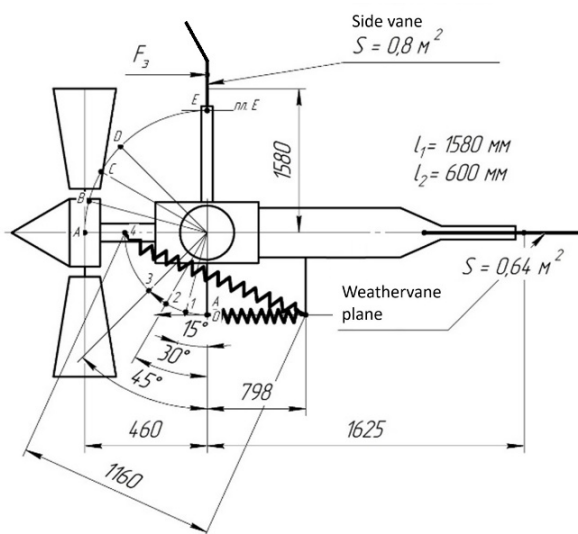

Fig. 2. Schematic of the calculation of WW run-out parameters out of the wind

For the maximum allowable wind speed, at which the side blade will almost completely (by 90°) take WW out of the wind, we take 18 m/s.

The resulting force acting on the side vane shield will be equal to:

$$F_3 = \frac{N}{\vartheta} \cdot S = \frac{3600 \cdot 0,5}{18} = 100 \text{ N} \tag{7}$$

where N is the second power of the flow according to Table 2.

$S = 0,5 \text{ m}^2$, the adopted area of the side vane screen (taken as an area factor other than the area equal to 1 m^2).

Maximum torque at that:

$$M_{max} = F_3 \cdot l_1 = 100 \cdot 1,58 = 158 \text{ N} \cdot \text{m} \tag{8}$$

All the current values of the moments created by the resultant force F_3 for different wind speeds are recorded in Table 4.

Table 4. Dependence of forces on the spring and the equality of moments from the action of forces on the side vane shield

Indicator	Current parameter values								
ϑ , m/s	4	6	8	9	10	12	14	18	22
F_3 , N	5	11	19	26	30	48	60	100	142
M_e , H·m	8	17	30	41	47	76	95	158	224
F_{sp}	13	29	50	68	79	126	158	263	374
h , mm	47	95	170	226	263	422	576	850	1340

Indicator	Current parameter values								
α , deg	3°	9°	18°	24°	28°	44°	88°	90°	90°
n_N , rpm	107	158	203	220	236	230	58	83	21
Q_N , m ³ /hour	0.9	1,33	1,7	1,85	1,98	1,93	0,5	0,7	0,17

Next, let us calculate the forces on the spring for its selection based on the equality of moments from the action of forces on the side vane shield M_e and on the spring M_{sp} , i.e.

$$F_e \cdot 1,58 = F_{sp} \cdot 0,6, \quad (9)$$

from which

$$F_{sp} = \frac{F_e \cdot 1,58}{0,6}, N$$

The results of the calculations are recorded in Table 4

It should be borne in mind that when WW runs out of wind, the wind flow will affect the screen of the side blade not perpendicular to the screen, but at a decreasing angle, which will lead to a decrease in the resulting force acting on both the screen and the spring. In this regard, we assume the initial position of the plane of the side vane screen at an angle of 45° to the oncoming airflow as shown in Fig. 2. In this case, until the rotation of the WW by an angle up to 45°, the force F_3 acting on the side blade shield will increase by the value of $\sin 45^\circ + \alpha$, then it will decrease by the value of $\cos \alpha$ until the WW is completely out of the wind. The results of the spring force calculations considering the initial position of the side vane shield at 45° are also recorded in Table 4.

The spring force at working deformation corresponding to the largest forced displacement of the movable link (point A, Fig. 2) in the mechanism corresponding to point E of the center of the center of WW completely taken out of the wind, let's assume equal to $F_2=186$ N (Table 4), which will correspond to the removal of the WW from the wind at an angle of up to 85°-90°.

Working stroke of the spring according to fig. 1 and assembly drawing made in scale 1:2, when reaching the angle of rotation of WW equal to 45°, we take $h = 850$ mm. This rotation of the power head with WW should correspond to a wind speed of 18-20 m/s.

Then we plot the spring elasticity (Fig. 3) by the points F_{sp} with the initial location of the side vane screen at an angle of 45° and the spring elongation h for each position of the movable link of the spring in accordance with the accepted angles of rotation of WW (from the assembly drawing). According to the obtained points, we draw an average line, which will be the required spring elasticity characteristic $F_{sp}=K \cdot h$,

where h is spring elongation, mm.

K is the coefficient of proportionality, equal to $tg \alpha$, where α is the angle of slope of the line of proportionality.

The results of measurements are recorded in Table 4 under letter symbols h (spring elongation) and α (angles of WW run out of the wind).

Then according to GOST 13765-86 for springs from steel of round section and design forces on the spring at given wind speeds we choose the parameters of the spring. The following calculations will be performed using the data [11].

The spring force at pre-deformation at a wind speed of 6 m/s is taken $F_1=24$ N.

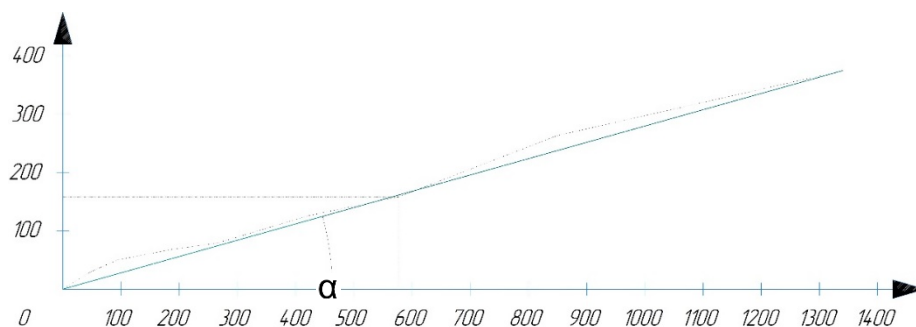

Fig. 3. Spring elasticity graph

The highest speed of the moving end of the spring during loading or unloading is assumed to be 0.3 m/s.

The outer diameter of the spring is assumed to be equal to $D_1 = 32$ mm (GOST 13776-86). Limiting the maximum spring deformation:

$$\delta = 1 - \frac{F_2}{F_3} = 1 - \frac{186}{374} = 0,5027 \quad (10)$$

where F_3 is the force of the spring at its maximum deformation occurring when turning the WW from the wind to 90° at wind speed up to 22 m/s. We accept $F_3 = 374$ N (table 4).

Spring force at maximum deformation:

$$F_3 = \frac{F_2}{1 - \delta} = 374 \text{ N.}$$

The prestressing force during spring coiling [11]:

$$F_0 = 0,25$$

$$F_3 = 0,25 \cdot 374 = 94 \text{ N.}$$

Wire diameter $d = 3,5$ (item 438 GOST 13766-86).

Outer diameter $D_1 = 32$ mm, stiffness of one coil $C_1 = 63,59 \frac{N}{\text{mm}}$, largest deflection of one coil $s_3 = 5,903$ mm.

Maximum tangential stress of the spring:

$$\tau_3 = K \cdot \frac{8F_3 \cdot D}{\pi d^3} = 1,2155 \cdot \frac{8 \cdot 374 \cdot 28,5}{\pi \cdot 3,5^3} = 633,5 \frac{N}{\text{mm}^2}, \quad (11)$$

Where:

$$K = \frac{4i-1}{4i-4} + \frac{0,615}{i} = \frac{4 \cdot 8,143 - 1}{4 \cdot 8,143 - 4} + \frac{0,615}{8,143} = 1,2155$$

$$\text{Spring index } i = \frac{D}{d} = \frac{28,5}{3,5} = 8,143$$

$$D = D_1 - d = 32 - 3,5 = 28,5 \text{ mm}$$

Critical spring rate:

$$\vartheta_K = \frac{\tau_3 \left(1 - \frac{F_2}{F_3}\right)}{\sqrt{2G\rho \cdot 10^{-3}}} = \frac{633,5 \left(1 - \frac{158}{374}\right)}{\sqrt{2 \cdot 7,85 \cdot 10^4 \cdot 8 \cdot 10^{-3}}} = 0,792 \frac{m}{s}, \quad (12)$$

$$0,792 > \text{accepted } 0,3 \frac{m}{s}$$

Dynamic material density for spring steel:

$$\rho = \frac{8 \cdot 10^3 n \cdot s^2}{m^4} \quad (13)$$

G- shear modulus, $G = 7,85 \cdot 10^4$

Spring stiffness:

$$C = \frac{F_2 - F_1}{h} = \frac{186 - 24}{850 - 93} = 0,2140 \frac{N}{\text{mm}}$$

$$C = \frac{Gd^4}{8D^3n}, \text{ from which } n = \frac{Gd^4}{C8D^3} = \frac{7,85 \cdot 10^4 \cdot 3,5^4}{0,2140 \cdot 8 \cdot 28,5^3} = 295$$

Initial spring length $l_0 = n \cdot d = 295 \cdot 3,5 = 1033$ mm.

The number of working coils of the spring $n = \frac{C_1}{C} = \frac{63,59}{0,2140} = 298$

Preliminary spring deformation at wind speed 6 m/s

$$S_1 = \frac{F_1}{c} = \frac{24}{0,2140} = 112 \text{ mm,}$$

that corresponds to the WW running out of the wind at the angle of $90^\circ - 11^\circ$.

Working deformation of the spring:

$$S_2 = \frac{F_2}{c} = \frac{186}{0,2140} = 870 \text{ mm,}$$

that corresponds to the WW run out to the angle equal to $85^\circ - 90^\circ$, at which the WW rotation frequency is significantly removed. Maximum spring deformation:

$$S_3 = \frac{F_3}{c} = \frac{374}{0,2140} = 1747 \text{ mm}$$

Maximum spring length at maximum deformation:

$$l_3 = l_0 + S_3 = 1033 + 1747 = 2780 \text{ mm.}$$

However, the maximum spring deformation when the WW plane is rotated by 90° will be 850 mm (from the design), as this value will be limited by the stop.

Consequently, the safety factor for the onset of plastic deformation of the spring is as follows $K_3 = \frac{S_3}{855} = \frac{1747}{850} = 2,055$

Spring weight (without hooks):

$$m \approx 19,25 \cdot 10^{-6} \cdot D \cdot d^2 \cdot n = 19,25 \cdot 10^{-6} \cdot 28 \cdot 3,5^2 \cdot 298 = 1,98 \text{ kg.}$$

Thus, a spring with the parameters:

$$D_1 = 32 \text{ mm}, d_1 = 3,5 \text{ mm},$$

$$C_1 = 63,59 \frac{\text{N}}{\text{mm}} \text{ (stiffness of one coil),}$$

$F_{sp3} = 374\text{N}$ at maximum stretching, spring stiffness $C = 0,2140 \text{ N/mm}$, initial spring length $l_0 = 1033 \text{ mm}$, number of turns $n=298$, maximum possible spring length at maximum deformation 2780 mm, the critical velocity of the moving end of the spring 0.792 m/s.

The adopted parameters of the spring satisfy the required technological characteristics. given in Table 4.

Next, let's calculate the nominal speed of n_N WW and the current performance when using the windward bias of the WW for the entire speed range.

Initial WW area at $\alpha = 0$

$$S = \frac{\pi \cdot D^2}{4} = \frac{\pi \cdot 2,6^2}{4} = 5,31 \text{ m}^2$$

When WW runs out of the wind, the initial area decreases relative to the airflow direction by $\cos(\alpha)$ (Fig.4)

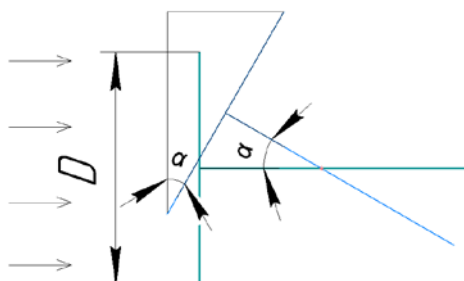

Fig. 4. Schematic to estimate the change in the area swept by the wind wheel when it's out of the wind

The power of the wind flow acting on the area swept by WW is determined considering the data in Table 2. At wind speeds up to 4 m/s, the flow capacity:

$$N_1 = 5,31 \cdot 0,04 = 0,212 \text{ kW}$$

The speed of rotation of the WW at this:

$$n_1 = \frac{60 \cdot x \cdot v_1}{\pi D} = \frac{60 \cdot 5,6 \cdot 4}{\pi \cdot 2,6} = 107 \text{ rpm}$$

Let's calculate the productivity of Q_1 by the formula:

$$Q_1 = \frac{60 \cdot v_N \cdot n_1 \cdot i}{1000} = \frac{60 \cdot 0,84 \cdot 107}{6 \cdot 1000} = 0,9 \text{ m}^3/\text{hour} \quad (14)$$

At wind speed of $v_1 = 4 \text{ m/s}$, the angle of rotation of the WW will be 3° (Table 4), which corresponds to the area swept by the WW.

$$S_1 = 5,31 \cdot \cos 3^\circ = 5,31 \cdot 0,9986 = 5,302 \text{ m}^2,$$

It can be considered that at $\alpha=3^\circ$, the WW area is practically unchanged. Therefore, the rotation frequency of WW (n_{N1}) can be taken as equal to the initial one $n_{N1}=107 \text{ r/min}$.

Similar calculations are performed for wind speeds of $v_2 = 6$ m/s the angle of rotation of WW will be $\alpha = 9^\circ$, $v_3 = 9$ m/s $\alpha = 24^\circ$, $v_4 = 10$ m/s $\alpha = 28^\circ$, $v_5 = 12$ m/s $\alpha = 44^\circ$, $v_6 = 14$ m/s $\alpha = 56^\circ$.

Reduction of rotation frequency cannot be estimated at wind speed equal to or greater than 13-14 m/s, because at this wind speed free rotation of WW is inadmissible, i.e., without its running out of the wind.

At a wind speed of 18 m/s $\alpha = 80^\circ$, which corresponds to the area swept by the WW.

$$S_8 = S \cdot \cos 80^\circ = 5,31 \cdot 0,1736 = 0,92 \text{ m}^2 \text{ m}^2$$

The power contained in an air stream having a cross-section of 1 m², $N_8 = 3,6$ kW/m²

Power developed by WW:

$$N = S \cdot N_7 = 5,31 \cdot 3,6 = 19,1 \text{ kW}$$

Out of functional connection:

$$5,31 \text{ m}^2 \rightarrow 19,1 \text{ kW}$$

$$0,92 \text{ m}^2 \rightarrow N,$$

$$N = \frac{0,92 \cdot 19,1}{5,31} = 3,31 \text{ kW}$$

A power of 19.1 kW corresponds to a wind speed of 18 m/s, and a power of 3.31 kW will correspond to a wind speed of

$$v = \frac{3,31 \cdot 18}{19,1} = 3,12 \text{ m/s}$$

The rotation frequency of n_8 will be:

$$n_8 = \frac{60 \cdot 3,63 \cdot 3,12}{\pi \cdot 2,6} = 83 \text{ rpm}$$

The reduction in WW speed cannot be estimated for the same reason as in the previous case.

At wind speed of 22 m/s $\alpha = 88^\circ - 90^\circ$, which corresponds to the minimum area swept by the WW

The obtained values of nominal WW speeds for different angles of WW run out of the wind and their corresponding nominal capacity under the letter symbols p_n and Q_n are entered in Table 4.

4 CONCLUSIONS

Based on a comparative analysis of horizontal-axis wind turbines during their operation in real conditions, and especially in wintertime, we can conclude that the most critical indicators are mainly performance and resistance to hurricane gusts of wind. An algorithm for solving the problem of ensuring the stable direction of the wind wheel plane towards the airflow and it's running out of the wind when it increases to speeds exceeding the maximum allowable operating wind speed is proposed. A methodology for calculating the reduction in wind wheel speed and the corresponding reduction in performance when the wind increases is presented. The general scheme and methodology of preliminary calculation and justification of required power, WW speed, and WPWLU productivity are presented. The following results were obtained: expected WPWLU power of 1.2 kW, WW diameter of 2.6 m, WW speeds from 133 rpm at wind speed of 4m/s to 288 rpm at 12m/s, capacity from 1.12 m³/h to 2.4 m³/h. As a result of mathematical transformations, the functional connection determining the force of the wind wheel running out of the wind is obtained. A methodology for calculating the spring that returns the WW to its initial position after it runs out of the wind when it is weakened is proposed. Specific correspondences between the WW run-out angle and the amount of spring extension are obtained.

5 REFERENCES

- [1] Decree of the Government of the Republic of Kazakhstan (October 12, 2021) On approval of the national project "Sustainable economic growth aimed at Improving the Welfare of Kazakhstan". no. 730.
- [2] Lim N., Zhanadilova J., Chadiarova D., Kim M. (2021). PWC. First edition. Overview of the renewable energy market in Kazakhstan: potential, challenges and prospects.
- [3] Bayray M., Kiros H., Abdelkadir M., (2015). Performance of Wind Pump Prototype. Momona Ethiopian Journal of Science. vol. 7, no. 2, 176-190, DOI: 10.4314/mejs.v7i2.3.
- [4] Chehour A., Younes R., Ilinca A., (2015). Review of performance optimization techniques applied to wind turbines. Applied Energy. vol. 142 ,361-388, DOI:10.1016/j.apenergy.2014.12.043.

- [5] Han Cao, (2011). Aerodynamics Analysis of Small Horizontal Axis Wind Turbine Blades by Using 2D and 3D CFD Modelling. Engineering and Physical Sciences at the University of Central Lancashire, Preston, England.
- [6] Ramzan Luhur M. (2016). A review of the state-of-the-art in aerodynamic performance of horizontal axis wind turbine. Wind and Structures. vol. 22, no 1, 1-16, DOI: <http://dx.doi.org/10.12989/was.2016.22.1.001>
- [7] Bekir Y. (2021). Water Pumping Systems with Wind Turbines in Sinop. European Journal of Science and Technology. no. 31, 515-522, DOI: 10.31590/ejosat.1010299.
- [8] Mathivanan S., Amrith S., Jemshid A., Anvar Sadik N. (2021). Design and Fabrication of Water Pumping Mechanism using Wind Energy. ETEDM. vol. 9, no. 10, 98-102, DOI: 10.17577/IJERTCONV9IS10025.
- [9] Global wind energy council. (2022). Global wind report.
- [10] Martin O. (2015) Aerodynamics of Wind Turbines. Third edition.
- [11] Malliotakis G., Nikolaidis N., Baniotopoulos C., (2020). Small wind turbines: Sustainability criteria related to the local built environment. IOP Conference Series: Earth and Environmental Science. vol. 410, 1–13. DOI:10.1088/1755-1315/410/1/012046
- [12] Abishev K., Assylova K., Kassenov A., Baltabekova A. (2023). Determination of the value of tangential force for the half-track traction vehicle with rubber tracks. Journal of Applied Engineering Science. vol. 21, no 2, 411–417, DOI: 10.5937/jaes0-39677
- [13] Dahham, A., Kasenov, A., Aljibory, M. (2023). Design parameters and mechanical efficiency of jet wind turbine under high wind speed conditions. Open Engineering. vol. 13, no. 1, 1-9, DOI: 10.1515/eng-2022-0450
- [14] Mitrovic C., Vorotovic G., Petrovic N., (2014). Advanced structural testing methods for small wind turbines blade up to failure. Journal of Applied Engineering Science. vol.12, 129-136, DOI: 10.5937/jaes12-5787
- [15] Ivanov K., Knol O., Balbayev G., (2014). Adaptive Transmission of Wind Turbine. American Journal of Mechanics and Applications. vol. 2, no. 6, 35-38, DOI: 10.11648/j.ajma.s.2014020601.17
- [16] Muhammad S., Wang Y., Muhammad B., (2020). Comparison of Small-Scale Wind Energy Conversion Systems: Economic Indexes Clean Technol. vol. 2, no. , 144-155, DOI: 10.3390/cleantechnol2020010
- [17] Nurkimbayev S.M., Shumeiko I.A. (2022). Highly efficient small-capacity wind power plant with storm protection. Bulletin of Toraigyrov University. Energetics series. vol. 3, 224-241, DOI: 10.48082/RRAK3496.
- [18] Nurkimbayev S.M, Shumeiko I.A., Kassenov A.Z. (2023) Choosing the Optimal Variant of the Shape and Relative Area of the Blade of the Wind Wheel of a Low-power Wind Power Plant. University Proceedings. Engineering. vol. 2, no. 91, 25-33, DOI: 10.52209/1609-1825_2023_2_25
- [19] Nurkimbayev S.M., Shumeiko I.A., Itybaeva G.T. (2023). Research and Justification of the Parameters of the Wind Wheel of a Low-power Wind Power Plant for Various Purposes. University Proceedings. vol. 3, no. 92, 72-78, DOI: 10.52209/1609-1825_2023_3_72
- [20] Nurkimbayev S.M., Shumeiko I.A., Itybaeva G.T. (2023). Calculation of the mechanism of autonomous control of the wind wheel rotation speed and storm protection. Science and technology of Kazakhstan. vol. 4, 90-101, DOI: 10.48081/JRHA6312

Paper submitted: 25.09.2023.

Paper accepted: 21.02.2024.

This is an open access article distributed under the CC BY 4.0 terms and conditions